

INSTALLATIEVOORSCHRIFTEN INSTRUCTION MANUAL

NTF® RADIAL MICRO FILTER

SERIE
OLFS

OLFS-58/6 Hydraulic

Congratulations with your purchase of this NTF® Radial Micro Offline Filter. To ensure optimum performance of this filtration system, please read this manual carefully.

1. Introduction	page 2
2. General description	page 2
3. Purpose	page 2
4. Safety regulations, risks and warnings	page 2
5. Operating instructions	page 3
6. Transport, storage and disposal	page 3
7. Installation and assembly	page 4
8. Maintenance instructions	page 5
9. Warranty	page 6
10. Hydraulic scheme	page 7
11. Technical specifications filter system	page 8
12. Technical specifications gear pump	page 9
13. Technical specifications motor	page 11
15. EU declaration of conformity	page 36



© 2017 NTF Filter

FOR HYDRAULIC APPLICATIONS

This NTF® Off-Line Filtration System (OLFS) can be applied on any hydraulic, lubricating and transmission system. The unit has been fitted with a dedicated motor and pump, thereby ensuring that system pressure and specifications stay within factory prescribed limits. The purpose of the OLFS is to pump oil from a reservoir (E.g. an oil sump), lead it through the filter and return filtered oil to the reservoir. Cleaner oil leads to less malfunctions and cost savings.

2. GENERAL DESCRIPTION

The OLFS has been modularly fitted on a manifold, in which all channels have been integrated, thereby minimizing the risk of oil leaks. The main advantage of the OLFS unit is that the filtration process takes place under constant flow and pressure. Because of this the efficiency is 10 times higher than of any in-line filter system. The results are:

- Cleaner oil
- Less malfunctions of the system the OLFS is fitted on.
- Less wear of the system the OLFS is fitted on.
- Prolonged life time of the system the OLFS is fitted on.
- Less oil consumption, better for the environment.



The OLFS is marked with

The OLFS has been constructed according to CE norm machinery directive.

3. PURPOSE

This OLFS filter system is specially designed for filtration of hydraulic and lubrication oil reservoirs.

4. SAFETY REGULATIONS, RISKS AND WARNINGS

Please keep the following in mind when installing the OLFS unit:

- Before assembling, connecting or servicing the OLFS unit, make sure that the application, on which the OLFS will be installed is safe to work on. If necessary, shut off electricity. Make sure that there is no oil pressure on the oil lines. If there is pressure, bring it down to 0 Bar.
- Use double steel-layered hydraulic hoses. They must be equipped with the appropriate connectors.
Do not use hoses for low-pressure applications.
- Make sure that the 3/4" return line from the OLFS to the tank has no pressure. Do **not use existing return lines.**
Use proper hydraulic connector materials. Do not use tape or sealing liquid!
- When starting up the system, make sure that the electro motor is rotating in the proper direction (clockwise).
- When replacing the filter elements or when oil spillage occurs, use the personal safety equipment, as prescribed in the Material Safety Data Sheet of the Oil .



Installation of this unit is only allowed to certified professionals engineers. In case of warranty claims certificates will be requested



The unit must be properly grounded to avoid any static electricity



Before switching on the unit **ALWAYS** check that there are no restrictions in the suction and return line. In case valves are installed in suction and or return line of the filter unit these valves should be opened **before** the unit is switched on.



When replacing the filter elements or when oil spillage occurs, use the personal safety equipment, as prescribed in the Material Safety Data Sheet. Check also personal safety regulations at site.

5. OPERATING INSTRUCTIONS (INCLUDING MOTOR)

The filter is functional when the motor is running. Installation should be done by certified electrical engineers. The user is responsible for the proper electrical wiring and installation of the filter unit. User must determine the appropriate guidelines as to when and how switch the unit to on and off. Additional information with regard to this point can be found under no.13 "Technical specifications motor".

6. TRANSPORT, STORAGE AND DISPOSAL

This OLFS-unit has been carefully packed to avoid damage during normal transport. Should your OLFS unit arrive damaged, please take pictures of the occurred damages and send these with a description to your NTF® dealer, so the damaged unit can quickly be replaced. There are no further special requirements for transport or storage.

When the OLFS unit or filter element is disposed off, the local regulations for disposing chemical waste should be taken into account.

- Before assembling and connecting the OLFS unit, make sure that the machine, on which the OLFS will be installed is safe to work on. If necessary, shut down electricity. Make sure that there is no system pressure.
If there is pressure, bring it down to 0 Bar.
- Mount the filter system on a vibration free spot.
- Keep hoses as short as possible. Do not bend or tense hoses.
- Make sure there is enough top side clearance (700 mm) after installation to have easy access for cartridge changes.
- Assure that the pressure gauge is properly accessible.
- The filter system should be installed in such a manner that enough space is available to connect the CM20 oil analysis equipment to the minimess sample connections.
- Connecting the OLFS unit must be carried out by qualified personnel.
- Assemble a connector to the suction side of the hydraulic pump and the return channel of the manifold.
Fit hose or pipe to these connectors.
- Create a suction hose (1/2" inside diameter) from the tank to the pump of the OLFS unit. Ensure that the suction port in the tank is always beneath the minimum oil level.
- To make the suction line use single or double steel-layered hydraulic hoses (inside diameter 1/2") equipped with the appropriate connectors. Do not use hoses for low-pressure applications.
- The 3/4" return line from the OLFS to the tank must be connected pressureless. Do not use existing return lines and keep the return line as short as possible! Ensure the returned oil flows back into the tank below the minimum oil level. Locate the return port on the tank in such a manner that oil in the tank circulates properly (suction and return port not to close together).
- Use proper hydraulic connector materials. Do not use tape or sealing liquid!
- Make sure that electrical connection complies with local installation and safety regulations. (connections as shown under point 12 « Technical specifications motor »).
- **Before switching on the unit ALWAYS check that there are no restrictions in the suction and return line.**
In case valves are installed in suction and or return line of the filter unit these valves should be opened before the unit is switched on.
- When using the minimess connectors on the manifold, ensure that the return line is pressureless.
- When starting the system, make sure that the motor is rotating in the proper direction (clockwise). This direction is also marked with an arrow on the motor. Checking the rotation direction can easily be done by looking at the cooling fan at the rear end of the motor. Rotating direction depends on wiring connections as shown under point 12 "Technical specifications motor". Prevent the access of any water, dirt or accessive dust in the electric motor.
- After starting the system, and after the first hour of operation, check for any leaks or abnormal sounds in the system. When the system shows leaks or any abnormal sounds, switch it off immediately. The cause should be determined and remedied before any further operation.

The required maintenance on an OLFS-unit consists of the timely and properly changing of the filter elements. Changing the filter elements should be done as follows:

- Only use original NTF® filter cartridges.
- Only use the supplied spare parts.
- The filter cartridges must be replaced when the pressure gauge indicates 5 Bar at operating temperature, or every 6 months, whichever comes first.
- Check for pressure on the tank. Relief the pressure of the system when necessary.
- Ensure that the filter system is pressureless when replacing the filter cartridges.
- Remove the filter cartridges and spare O-rings from the packaging.
- Remove the lids from the system and take out the pressure plates with springs.
- Remove the used filter cartridges and place it in the plastic bags for proper disposal. Place the new filter cartridges in the filter systems and place the pressure plates with springs back on the filter cartridges. Replace the O-rings, clean the sealing surfaces and put the lids back on the filter system. Tighten the inner hexagon bolts with a torque of minimal 9 Nm and maximal 12 Nm.
- Start the system until it has reached its operating temperature and check for leakages.
- Check the oil level in the system and top up the necessary quantity, if necessary.
- Check if the oil runs through the filter properly. If the hoses and the filter housings warm up, the filter system operates properly.
- When using the minimess connectors on the manifold for oil analysis, make sure that the return line is pressureless.

1. HOUSING

NTF® grants a 3-year limited warranty on the NTF® filter housing (excluding the accompanying o-rings) from the date of invoice. In the unlikely event that the purchaser finds a defect, the purchaser must notify their NTF® dealer. If the defect is justified, the NTF® filter housing will be replaced or repaired free of charge. Any claims to NTF® filter housings should be addressed directly to your NTF® point of contact. A claim should contain a clear description of the findings, including pictures and specifications of the application, along with a copy of the invoice.

2. EXTENDED OIL LIFE / DRAIN INTERVALS

When properly installed, NTF® guarantees the effective filtering operation of the NTF® filter and its positive effects for the equipment. Extended oil drain intervals are achievable with the proper use of the NTF® system. However, the condition of the oil and the oil change intervals are also dependent upon the original equipment manufacturer, operating conditions, selection of lube/oil, and system type. Due to conditions out of the control of NTF®, the length of any extended drain interval is at the discretion of the customer. The customer should perform regular oil analysis to ensure that the condition of the oil is within the recommended specifications as set by the original equipment/oil manufacturer. Upon request, NTF® can aid in this activity.

3. EQUIPMENT WARRANTY

In the unlikely event of material damage to the equipment, NTF® warrants the entire cost of repair under the following conditions (Documentation of which is the full responsibility of the claimant):

- The equipment is well maintained and worked properly at the moment of installation which can be proven by copies of the maintenance and repair history of the equipment.
- The NTF® filter is installed by a certified mechanic.
- The user must demonstrate the device damage is due to the malfunction of a properly installed and properly used NTF® filter system.
- The customer must demonstrate from actual data or from a documented extended drain interval program (historical data) that the oil or lube fluid in the device was within the proper usage specifications at time of failure.

4. LIABILITY

The above mentioned warranty and NTF's liability does not extend beyond (the consequences of) defects in the NTF® filter. Damage as a result of other means or caused by third parties, such as by errors during installation, by incorrect mounting onto the oil circuit or by mounting devices or hoses are not covered, neither by this warranty nor by NTF's product liability. With regard to mounting pieces supplied by NTF® the warranty applicable is the warranty of the suppliers/producers of the mounting pieces which is passed on by NTF® to its customers. Liabilities are limited to the amounts mentioned in the insurance policy for liability risks that NTF® has concluded with N.V. Interpolis. No claim shall exceed Euro 2.500.000. The maximum annual amount of damages covered shall not exceed Euro 5.000.000.

5. BREACH OF WARRANTY POLICY

The warranty is non-applicable or breached by user if and when:

- The NTF® filter is handled without due care or in contradiction with the instructions for use, or if used for purposes other than its appropriate purpose.
- Cartridges other than original NTF® filter cartridges have been applied.
- No valid dated purchase invoice can be produced.
- The defect and/or the damage is a result of a natural disaster, accident, misuse, incorrect use or any other outside cause for which NTF® is not liable.

In case of disputes Dutch law is applicable.

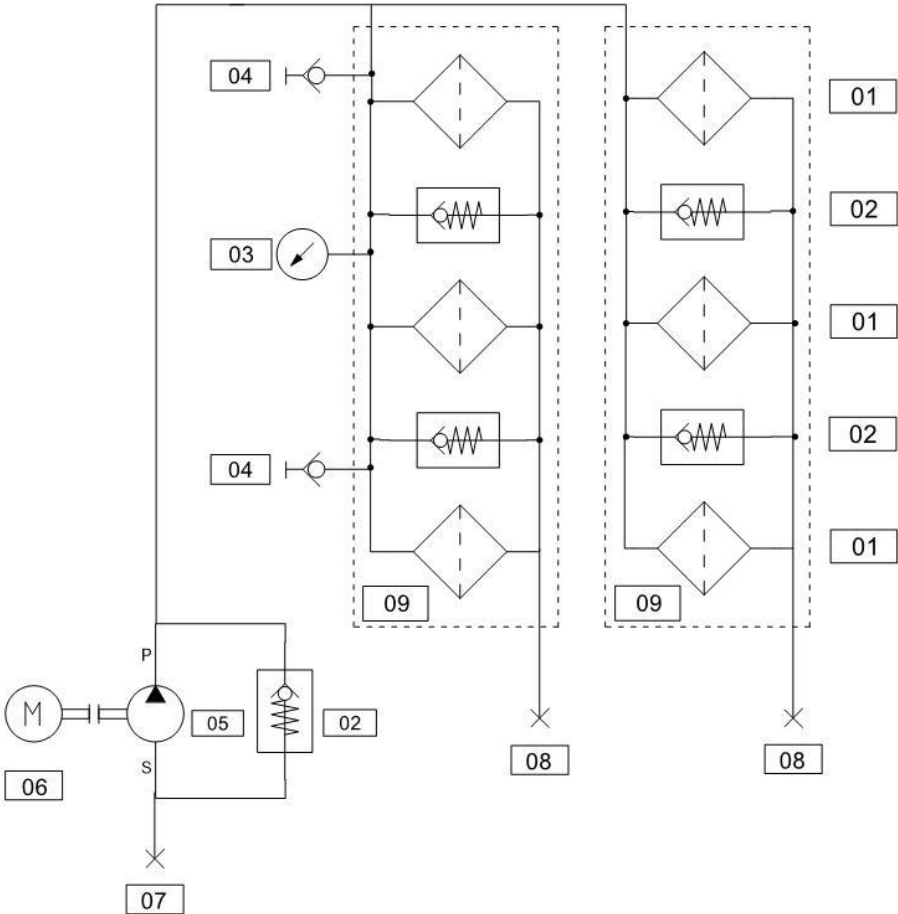

- 01 Micro Filter F58
- 02 Check valve settings 5.5 Bar
- 03 Pressure gauge
- 04 Connection point for sample or particle counter
- 05 Hydraulic gear pump
- 06 Electric motor
- 07 Connection suction side 15L
- 08 Connection return pipe 15L
- 09 Manifold 3x AL 58 filter units

Filter type	OLFS-58/6
Application	Hydraulic
Pump:	
Type	Gear pump
Displacement	Several pumps possible
Connection suction side	1/2 BSP i.d.
Diameter suction hose	1/2 "
Seals	Buna NBR
Max. Temperature	80° Celsius
Electric motor:	
Power supply	several tensions available
Norm	IEC/DIN-VDE 530
Protection rating	IP55
Filter/manifold:	
Filter efficiency	Beta (β) 4 > 10649
Dimensions filter element	Ø 78 x 600 mm (6 pce)
Nominal flow	Depending on application
Material filter housing	Anodized aluminium
Max. pressure housing	25 Bar
Max. temperature	80° Celsius
Indicator	Press. gauge
Connection return	M22 x 1,5
I.D. Return hose	3/4 "
Seals	Buna NBR
Bypass setting	5.5 Bar
Connections monitor	1/8 BSP > M16X2
Complete unit:	
Weight	90 kg approx.
Dimensions (hxwx d)	1020 x 600 x 320 mm



Replaces: 01/10.03

FEATURES

Construction	External gear type pumps and motors
Mounting	EUROPEAN - SAE - GERMAN standard flanges
Line connection	Screw and flange
Direction of rotation (looking on drive shaft)	Anti-clock (S) - clockwise (D) - reversible external drain (L - R) reversible internal drain (B)
Inlet pressure range for pumps	10 ÷ 44 psi [0,7 ÷ 3 bar (abs.)]
Max back pressure for single rotation motors and reversible internal drain motors	p_1 (continuous) max 73 psi (5 bar)
	p_2 (for 20 s) max 116 psi (8 bar)
	p_3 (for 8 s) max 218 psi (15 bar)
Max drain line pressure on the reversible rotation motors	73 psi (5 bar)
Max back pressure on the series motors (reversible motors external drain)	$< p_1$ (max continuous pressure) < 2175 psi (< 150 bar)
Fluid temperature range	See table (1)
Fluid	Mineral oil based hydraulic fluids to ISO/DIN. For other fluids please consult our technical sales department.
Viscosity range	From 60 to 456 SSU [12 to 100 mm ² /s (cSt)] recommended
	Up to 3410 SSU [750 mm ² /s (cSt)] permitted
Filtering requirement	See table (2) page 4

Tab. 1

Type	Fluid composition	Max pressure psi - (bar)	Max speed min ⁻¹	Temperature °F - (°C)			Seals (●)	Special shaft seals (◆)
				Min	Max continuous	Max peak		
ISO/DIN	Mineral oil based hydraulic fluid to ISO/DIN	See page 3	See page 3	-13 (-25)	176 (80)	212 (100)	N	D - H - C
				-13 (-25)	230 (110)	257 (125)	V	D

(●) N= Buna N (standard) - V= Viton

◆ Shaft seals max pressure and mounting scheme

	D	H	C
	Standard shaft seal with wiper seal	High pressure special shaft seal	High pressure special shaft seal with wiper seal
Single rotation pumps	Max 44 psi (3 bar) DCAT_033_037 	Max 363 psi (25 bar) # DCAT_033_039 	Max 363 psi (25 bar) # DCAT_033_036
Single rotation motors Reversible rotation pumps and motors	Max 44 psi (3 bar) DCAT_033_038 	DCAT_033_039 	DCAT_033_036

Pressure could change in connection with shaft speed rotation.
For more information please consult our technical sales department.

02/07.2006

Replaces: 01/10.03

FEATURES



Construction	External gear type pumps and motors
Mounting	EUROPEAN - SAE - GERMAN standard flanges
Line connection	Screw and flange
Direction of rotation (looking on drive shaft)	Anti-clock (S) - clockwise (D) - reversible external drain (L - R) reversible internal drain (B)
Inlet pressure range for pumps	10 + 44 psi [0,7 + 3 bar (abs.)]
Max back pressure for single rotation motors and reversible internal drain motors	p_1 (continuous) max 73 psi (5 bar)
	p_2 (for 20 s) max 116 psi (8 bar)
	p_3 (for 8 s) max 218 psi (15 bar)
Max drain line pressure on the reversible rotation motors	73 psi (5 bar)
Max back pressure on the series motors (reversible motors external drain)	$< p_1$ (max continuous pressure) < 2175 psi (< 150 bar)
Fluid temperature range	See table (1)
Fluid	Mineral oil based hydraulic fluids to ISO/DIN. For other fluids please consult our technical sales department.
Viscosity range	From 60 to 456 SSU [12 to 100 mm ² /s (cSt)] recommended
	Up to 3410 SSU [750 mm ² /s (cSt)] permitted
Filtering requirement	See table (2) page 4

Tab. 1

Type	Fluid composition	Max pressure psi - (bar)	Max speed min ⁻¹	Temperature °F - (°C)			Seals (●)	Special shaft seals (◆)
				Min	Max continuous	Max peak		
ISO/DIN	Mineral oil based hydraulic fluid to ISO/DIN	See page 3	See page 3	-13 (-25)	176 (80)	212 (100)	N	D - H - C
				-13 (-25)	230 (110)	257 (125)	V	D

(●) N= Buna N (standard) - V= Viton

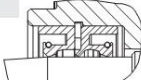
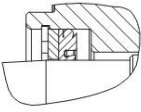
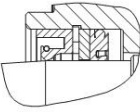
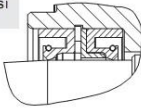
◆ Shaft seals max pressure and mounting scheme

	D	H	C
	Standard shaft seal with wiper seal	High pressure special shaft seal	High pressure special shaft seal with wiper seal
Single rotation pumps	Max 44 psi (3 bar) DCAT_033_037 	Max 363 psi (25 bar) # DCAT_033_039 	Max 363 psi (25 bar) # DCAT_033_036 
Single rotation motors Reversible rotation pumps and motors	Max 44 psi (3 bar) DCAT_033_038 	DCAT_033_039 	DCAT_033_036 

Pressure could change in connection with shaft speed rotation. For more information please consult our technical sales department.

02/07.2006

CONTENTS

	Page
Introduction.....	2
Electro-magnetic compatibility.....	2
1. Safety warning.....	2
1.1 Danger.....	2
1.2 Standards and specifications.....	3
2 Storage and installation.....	4
2.1 Control.....	4
2.2 Storage procedure.....	4
2.3 Installation.....	4
3 Operation.....	6
3.1 Initial Controls.....	6
3.2 Control of Design Data.....	7
3.3 Starting.....	8
3.4 Conditions of Use.....	8
4 Maintenance.....	9
4.1 Inspection.....	9
4.2 Lubrication.....	10
4.3 Disassembling and Reassembling.....	10
4.4 Bearing Replacement.....	10
4.5 Repairs and Overhuals.....	11
5 Troubleshooting.....	12
Table.....	15

2010

WONDER[®]

Introduction

The electrical machines referred to in these Instructions are intended as components for use in industrial areas. The information contained in this documentation is designed for use by qualified personnel who are familiar with the current rules and regulations in force. They are not intended to replace any installation regulations issued for safety purposes. In terms of Directive 89/392/CEE low voltage motors are to be considered as components to be installed on machines. Commissioning is forbidden until the final product has been checked for conformity.

Electro-magnetic compatibility

Low voltage induction motors, if installed correctly and connected to the power supply, respect all immunity and emission limits as set out in the regulations relating to electro-magnetic compatibility (EMC "Generic Standard" for industrial environments).

In the case of supply by means of electronic impulse (inverters, soft starters etc.), all verifications and any modifications necessary to ensure that emission and immunity Limits stated within the regulations are respected, are the responsibility of the installer.

Motors for classified areas

Motors to be used in dangerous areas are designed in compliance with European standards, using protection methods that are suitable for guaranteeing safety in areas subject to risk of fire and explosion. Where these motors are used improperly or modified their safety may be impaired.

1. General safety warnings

1.1 Danger

Rotating electric machines are dangerous. Therefore:

- improper use
- removal of protection and disconnection of protection devices
- Lack of inspection and maintenance can cause serious harm.

The personnel must be informed of any danger caused by contact with:

- ⚠ - live parts
- ⚠ - rotating parts
- ⚠ - hot surfaces. In normal working conditions the motor exceeds 50 °C.

The safety manager must ensure and guarantee that:

- the machine is moved, installed, put in service inspected, maintained and repaired only by qualified personnel, who should have:
 - specific technical training and experience
 - knowledge of technical standards and applicable laws
 - knowledge of general safety regulations as well as national, local and installation regulations
 - ability to recognize and avoid all possible dangers.

Work on the electric machine should be carried out upon authorization of the safety manager after having ensured that:

- a) the motor has been disconnected from the power supply and that no parts of the motor including auxiliary parts are live
- b) discharge of the capacitor has been done for single phase motors
- c) the motor is completely stopped and there is no danger of accidental restarting
- d) the right precautions against faulty braking operations have been taken for self-braking motors

⚠ where thermal protection with automatic reset is used care must be taken to ensure automatic restart cannot occur. Since the electric machine referred to is intended to be used in industrial

areas, additional protective measures must be taken and guaranteed by the person who is in charge of installation where more stringent protective measures are needed.

1.2 Standards and specifications

Title	INTERNATIONAL	EU	I	GB	F	D
	IEC	CENELEC	CEI-EN	BS	NFC	DIN/VDE
Electrical rotating machines/rated operation and characteristic data	IEC 60034-1	EN 60034-1	CEI-EN 60034-1 (CEI 2-3)	BS 4999-1 BS 4999-69	NFC 51-100 NFC 51-111	VDE 0530-1
Methods for determining losses and efficiency of rotating electrical machinery	IEC 60034-2	EN 60034-2	CEI-EN 60034-2 (CEI 2-6)	BS 4999-34	NFC 51-112	VDE 0530-2
Protection types of rotating electrical machines	IEC 60034-5	EN 60034-5	CEI-EN 60034-5 (CEI 2-16)	BS 4999-20	NFC 51-115	VDE 0530-5
Cooling methods of rotating electrical machines	IEC 60034-6	EN 60034-6	CEI-EN 60034-6 (CEI 2-7)	BS 4999-21	IEC 34-6	DIN IEC 34-6
Construction types of rotating electrical machines	IEC 60034-7	EN 60034-7	CEI-EN 60034-7 (CEI 2-14)	BS 4999-22	NFC 51-117	DIN IEC 34-7
Terminal markings and direction of rotation for electrical machines	IEC 60034-8	EN 60034-8	CEI 2-8	BS 4999-3	NFC 51-118	VDE 0530-8
Noise emission, limit values	IEC 60034-9	EN 60034-9	CEI-EN 60034-9 (CEI 2-24)	BS 4999-51	NFC 51-119	VDE 0530-9
Start-up behaviour of squirrel-cage motors at 50 Hz up to 660V	IEC 60034-12	EN 60034-12	CEI-EN 60034-12 (CEI 2-15)	BS 4999-112	IEC 34-12	VDE 0530-12
Vibration severity of rotating electrical machines	IEC 60034-14	EN 60034-14	CEI-EN 60034-14 (CEI 2-23)	BS 4999-50	NFC 51-111	DIN ISO 2373
Fixing dimensions and outputs for IM B3	IEC 60072	EN 50347	IEC 60072	BS 4999-10	NFC 51-104/110	DIN 42673
Fixing dimensions and outputs for IM B5, IM B14	IEC 60072	EN 50347	IEC 60072	BS 4999-10	NFC 51-104/110	DIN 42677
Cylindrical shaft ends for electrical machines	IEC 60072	EN 50347	IEC 60072	BS 4999-10	NFC 51-111	DIN 748-3
Electrical equipment for hazardous areas General provisions	IEC 60079-0	EN 60079-0	(CEI 31-8)	BS 5501-1	NFC 23-514	VDE 0171-1
Electrical equipment for hazardous areas Flame-proof enclosure "d"	IEC 60079-1	EN 60079-1	(CEI 31-1)	BS 5501-5	NFC 23-518	VDE 0171-5
Electrical equipment for hazardous areas Increased safety "e"	IEC 60079-7	EN 60079-7	(CEI 31-7)	BS 5501-6	NFC 23-519	VDE 0171-6
Checking and maintenance of electrical systems in places in danger of explosion due to the presence of gas	IEC 60079-17	EN 60079-17	CEI EN 60079-17	----	----	----
Electrical systems in places in danger of explosion due to the presence of gas	IEC 60079-14	EN 60079-14	CEI EN 60079-14	----	----	----
Classification of dangerous places due to the presence of gas	IEC 60079-10	EN 60079-10	CEI EN 60079-10	----	----	----
Checking and maintenance of electrical systems in places in danger of explosion due to the presence of dust	IEC 61241-17	EN 61241-17	CEI EN 61241-17	----	----	----
Electrical systems in places in danger of explosion due to the presence of dust	IEC 61241-14	EN 61241-14	CEI EN 61241-14	----	----	----
Classification of dangerous places due to the presence of dust	IEC 61241-10	EN 61241-10	CEI EN 61241-10	----	----	----

2. Storage and installation

2.1 Control

The motors are shipped ready for installation. Upon receipt, remove packaging and turn the shaft to check the motor has not been damaged, also check all physical aspects of the machine for damage. In the case where the machine is damaged, an immediate notification must be given in writing by the storeman and the representative of the carrier to Wonder within 3 days.

2.2 Storage procedure

2.2.1 Storage conditions

If the motors are not used immediately, they should be stored in a clean, dry temperature environment free of vibrations and protected from the weather. (If stored below -15°C, and before starting, the motor temperature must be restored to the permissible working temperature range (i.e. -15°C → 40°C). In this case, it is necessary to specify these particular storage conditions during the ordering stage so that proper precautions can be taken during building and packaging.

2.2.2 Checking bearings

When the motors are stored properly, no maintenance is needed. However, it is a good idea to turn the shaft by hand every three months. After storage of over one year, motors with unshielded bearings (usually such motors have a lubricator and bear a lubrication plate). It is advisable to check the condition of the lubrication and motor components.

2.2.3 Checking insulation

Before installation, check the motor windings using the appropriate instruments to ensure the condition of the insulation between phases and between phase

and earth are of the correct resistance values.

⚠ Do not touch the terminals during and immediately after measuring as they are live. If the insulation resistance value is less than 10 megaohm or after storage in a damp environment, the motors must be dried in an oven for about 8 hours by gradually bringing the temperature up to 100°C. To ensure that the dampness has been completely expelled, the motors must be dismantled.

2.2.4 Operating precautions

All operations listed above must be carried out by qualified personnel. In case of flame-proof motors, it is necessary:

- to be very careful the flame-proof characteristics are not altered
- to have the procedure described in point 2.2.2 carried out by authorized repair shops
- to be aware that dismantling or opening of the motor during the warranty period without authorization of Wonder may invalidate the warranty.

2.3 Installation

⚠ ⚠ Work on the electric machine must be carried out when the machine has stopped and been disconnected from the power supply (including auxiliary parts, such as anticondensation heaters).

2.3.1 Lifting

Before using the lifting rings, make sure they have been tightened.

⚠ **The lifting rings are big enough to bear the weight of a single motor, therefore they must not be used to lift the equipment connected to the motor.**

In environments where the temperature is below -20°C, these lifting rings should

be used with caution as they could break at low temperatures and cause damage.

2.3.2 Assembly of connecting device

Fitting pulley, coupling or gear to the motor shaft must be carried out with care to ensure no damage is caused to the bearing. Remove the protective paint finish from the shaft and smear with oil then fit the device, heating before fitting if possible to ensure an easy fit.

Any component that is assembled on the motor shaft must be accurately balanced.

The motor is normally balanced using a half key and the letter H is punched on the shaft.

Fittings not balanced properly can cause anomalous vibrations during operation that jeopardises the proper working of the motor and drastically reduces its life.

2.3.3 Direct connection

Use couplings that have been made and balanced perfectly align the motor shaft and the operating machine precisely. Inaccurate alignment may cause vibrations and damage to the bearings or breakage of the shaft end.

2.3.4 Connection by means of pulley

Check that alignment with the pulley of the operating machine has been carried out perfectly. The tension of the belts must be enough to avoid slipping. Excessive tension of the belts causes harmful radial loads on the motor shaft and bearings, reducing their life.

It is advisable to assemble the motor on belt-tensioning slides in order to regulate tension of the belts exactly.

⚠ Connection with belts must be such as to avoid accumulation of static charges in the moving belts which could cause sparks.

2.3.5 Connection to power supply

Use cables with sufficient section to bear the maximum current absorbed by the motor, avoiding overheating and /or drops in voltage. Connect the cables to terminals by following the instructions on the plate or on the diagram included in the terminal box. Check that terminal nuts are tightened.

⚠ **Connections to the terminals must be made in order to guarantee safe distances between live uncovered parts.**

⊥ Earthing is through the screw located inside the terminal box. Flame-proof motors are provided with a second earth stud located on the motor casing outside the terminal box. Earths must be of sufficient size and installed according to relevant standards. The area of contact of connections must be cleaned and protected against corrosion.

When the cable inlet is made by means of a cable gland, it must be chosen properly in relation to the type of plant and type of cable used. The cable gland must be tightened so that the retaining rings create the pressure necessary to:

- a) prevent transmission of mechanical stress to the motor terminals
- b) ensure the mechanical (IP degree) protection of the terminal box.

For flame-proof motors the cable inlet must be made by complying with the regulations in point 13 of the standard IEC 60079-1. Apertures not used must

be closed in accordance with specifications in point 13 of the same standard.

When reassembling the terminal cover make sure that if there is a seal, and it is in the right place. Flame-proof motors do not have a seal so before reassembling the terminal box it is necessary to replace the layer of grease. The terminal box cover must be tightened to ensure it is properly sealed.

2.3.6 Connection of auxiliary parts

a) thermal protection

Check which type of protection is installed before making connections. If thermistors (PTC) are used, it is necessary to utilize a suitable relay. Do not apply a tension over 6V during the thermistor continuity test.

b) anti-condensation

If the motor is fitted with anti-condensation heaters, their power supply must be separated from that of the motor, using the terminals housed in the terminal box.

⚠ WARNING: the supply of the heater is always monophase and the voltage is different from that of the motor. Check that it corresponds to the one indicated on the plate.

c) auxiliary ventilation

Connect the supply of the auxiliary ventilation motor separately from that of the main motor.

⚠ WARNING: use a device that allows starting and operation of the main motor only when the auxiliary fan is working

2.3.7 Fixing to the base

The bolts fixing the motor to the base must be fitted with washers that they ensure adequate load distribution.

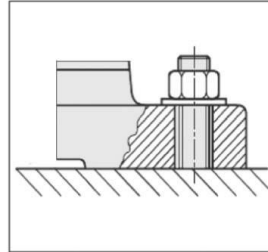

3. Operation

⚠ it is the responsibility of the installer to establish the motor's fitness to be used in a certain plant, after analysing the characteristics of danger existing in the installation area with respect to current provisions of the law and to those issued for safety purposes.

3.1 Initial Controls

Before starting the motor it is important to check that:

- installation has been carried out properly
- the bearings have not been damaged during installation
- the motor base is sturdy enough and the foundation bolts have been tightened
- the design data corresponds to those given on the plate and in the technical documentation

⚠ The electric motor is a component made to be mechanically connected to another machine (single or part of a plant). Consequently, it is the task of the person responsible for the installation to guarantee that during operation there is an adequate degree of protection for

people or things against the danger of accidental contact with moving parts.

3.2 Control of Design Data

Make sure that the motor is suited for use in the working conditions foreseen and check the following:

3.2.1 Environmental conditions

- a) ambient temperature: standard closed motors can operate between -15°C and $+40^{\circ}\text{C}$.
- b) altitude:
normal motors have been designed to work between 0 and 1.000 m above sea level
- c) protection against the presence of harmful agents like: sand, corrosive substances, dust and/or fibre, water, mechanical stress and vibrations
- d) mechanical protection:
installation inside or outside considering the harmful effects of the weather, the combined effect of temperature and humidity and the formation of condensation
- e) adequate space around the motor especially on the fan side to allow proper ventilation
- f) motors mounted in the vertical, shaft down require a protective cowl over the fan inlet
- g) any danger of explosion or fire.

3.2.2 Working conditions.

- a) The motor must only be assembled and operated in the construction form indicated on the motor plate.
- b) operation type:
the motors are normally for S1 duty continuous operation
- c) load type:

carefully evaluate machines with high moments of inertia and the relative starting times

- d) for motors intended for operation in hazardous areas (Ex d or Ex e) the motor type and temperature classification must comply with the area rating
- e) for self-braking motors see the special applications envisaged in the relative catalogue.

3.2.3 Electrical characteristics

- a) voltage and frequency should correspond to those on the plate
- b) motor power should be adequate as required by the load
- c) power supply protection against overloads and/or short circuits should be adequate for the nominal current and starting current
- d) for connection to control circuits follow the connection diagram supplied with motor (Table A)

 Abnormal working conditions must always be defined when placing order to ensure that the site conditions are not prejudicial to the proper operation of the machine.

3.2.4 Other checks before commissioning

- Check that the motor rotates in the correct direction, and that when the inverter is activated the speed limit is not exceeded.
- Check that the motor is protected as prescribed in the standards.
- When using a star/delta starter, to avoid the risk of overloading make sure that the switch over from star to delta only takes place when the starting

current has been adequately reduced.

- Check that any auxiliary accessories are working.

3.3 starting

3.3.1 Earthing connection

Before starting the motor ensure that the incoming supply cables are connected correctly

3.3.2 Motors with auxiliary ventilation

For motors with forced ventilation by means of external ventilation make sure that the motor starter is interlocked with the contactor of the external ventilator to ensure the fan is operational.

3.3.3 Start up

When all previous checks have been made satisfactorily, the motor may be started. Unless otherwise stated all motors can be direct on line started. If you intend to start the motor by means of static starters, rheostats or the star-delta system, they must be chosen and set properly to avoid incorrect functioning of the motor.

3.4 Conditions of Use

3.4.1 Working features

Once the motor has started it is necessary to check that during operation the working conditions remain within the limits envisaged, and that the following does not occur.

- overload
- rise in environmental temperature
- excessive drop in voltage

Every time there is a change in the working conditions, it is necessary to check that the complete fitness of

the motor has been maintained for the new operating conditions.

For example:

- variation in working cycle
- the function of the motor has altered
- moving of the motor to a different environment
- moving of the motor to a higher temperature environment.

3.4.2 Restarting after long rest

Before starting the motor after a long resting period, repeat the controls described in section 2.2.2 and

2.2.3.

Where supplied, heater must not be energised when the motor is running.

3.4.3 Anomalous conditions

The motor must be used only for applications it was designed for and must be utilized and controlled complying with the precautionary standards.

 If the machine shows anomalous working characteristics (greater absorption, increase in temperature, noisiness, vibrations), inform the personnel in charge of maintenance immediately.



3.4.4 Protection against overloading

In terms of the IEC.60079-14 standard all motors are to be protected using a suitable switch, such as one with a delayed trip that is triggered by the current, as well as protection in case of a phase going down. The protective device is to be set at the nominal current shown on the plate. This device must be chosen so that the motor is protected thermally if the rotor jam.

The windings connected in delta must be protected in such a way that the

switches or relays are connected in series with the winding phase. Switches are to be chosen and set taking the nominal phase current, that is, 0.58 times the motor's nominal current, as the base value.

4. Maintenance

  Any operation on the motor must be carried out with the machine stopped and disconnected from the power supply (including auxiliary circuits, especially the anticondensation heaters).

Maintenance of the original characteristics of electric machines over time must be ensured by a schedule of inspection, maintenance and setting up managed by qualified technicians. The type and frequency of maintenance depends on environmental and working conditions. As a rule, it is recommended that the first inspection is made after about 500 hours of operations or within 1 year, while subsequent inspections should follow the schedules established for lubrication and general inspection.

4.1 Checking

4.1.1 Normal working

Check that the motor works normally without anomalous noise or vibrations, If it does not, locate the cause of the anomaly.

4.1.2 Cleaning the surface

Make sure that the ventilation is not obstructed.

Clean the motor by removing any dust or fibre deposits from the fins and from the fan cover.

4.1.3 Checking the supply and earthing cable

Check that the supply cable does not show signs of wear and that the connections are tight. Make sure that the earth and

supply cables are not damaged.

4.1.4 Transmission elements

Check that the transmission elements are in perfect condition and that the screws and nuts are tight.

4.1.5 Protection against water

When the motor is installed in a very damp environment or is subject to drips of water, check regularly that the seal and retaining devices work efficiently. Ensure that there are no infiltrations inside the casing or terminal box.

4.1.6 Drainage devices

The motors furnished with drainage devices should be checked and cleaned regularly so that such devices continue to work properly.

4.1.7 Thermal protection

Make sure that thermal protections have not cut out and have been set properly.

 The right selection and setting of thermal protections for Ex e motors is essential to guarantee the temperature class and safety against the danger of explosion.

4.1.8 Unauthorized modifications

Check that no modifications have been made that alter the electric and mechanical operation of the motor.

4.1.9 Painting

When the motor is installed in an environment where there are corrosive agents it is recommended to paint the motor itself to protect the outer surfaces from corrosion if necessary.

4.1.10 Reconditioning operations

Every irregularity of fault found during inspection must be fixed immediately.

4.2 Lubrication

4.2.1 Permanently lubricated bearings

Motors with shielded or sealed bearings do not require lubrication. They do not require maintenance if used properly.

4.2.2 Bearings with lubricator

Motors with unshielded bearings are furnished with lubricators. The interval time between lubrications depends on the type of grease, environmental temperature, (any excessive working temperature) and type of operation the motor carries out. The table B show the intervals foreseen for 70°C as a working temperature of the bearings in normal operating conditions. It is recommended to use a good quality lithium based grease with great penetration capacity and high dropping point. If the velocity is different from the one given in the table, the intervals must be modified in inverse proportion.

Eg. bearing 6314 at 1.800 RPM

$$1 = \frac{1500}{1800} \times 3550 \text{ h} = 2950 \text{ h}$$

Regardless of working hours, the grease must be renewed after 1 or 2 years or during a complete overhaul. When the motor is furnished with a lubrication plate, refer to the dates shown on it.

4.3 Disassembling and Reassembling

All operations must be carried out conforming health and safety regulations.

4.3.1 Consulting the catalogue

Before working on the motor it is advisable

to consult the relevant catalogue and have all the tools ready.

4.3.2 Disconnection from power supply

Before proceeding with dismantling, the motor must be disconnected from the power supply. Make sure that the power is off, disconnect supply cables and auxiliary cables if any.

4.3.3 Placing on workstand

In order to work on the motor satisfactorily it should be removed from its mounting and placed on a work stand.

4.3.4 Disassembling procedure

Take off the fan cover by removing the screws.

Use an extractor to remove the cooling fan, Remove the end shields and withdraw the rotor being careful not to damage the windings. Precautions must be taken with flameproof motors so that the spigots on the frame and the end shields are not damaged. When the motor is dismantling and before it is reassembled it is necessary to protect the various components (particularly the bearings and windings) to avoid damage caused by dust or knocks.

4.3.5 Additions for self-braking motors

For dismantling for self-braking motors follow the instructions shown in the relative catalogue.

4.4 Bearings Replacement

4.4.1 Dismantling of bearings

- a) Bearings interference fit to shaft:
 - remove the bearings with the aid of a suitable extractor.
- b) Bearings interference fit to end shield:
 - heat end shield to a temperature between 140 and 160°C and then remove the bearings with the aid of

a suitable extractor.

In both cases, check that the respective housings have not been damaged. Then proceed with fitting the new bearings, these should be identical to those being replaced.

4.4.2 Fitting new bearings

- a) Bearings interference fit to shaft: heat the bearings to 120-130°C and push them quickly onto the shafts. If required, use a mallet and a brass sleeve, this must rest on the inner race of the bearing. Alternatively, if it is not possible to heat the bearings, we recommend using a press and a suitable sleeve which must rest on the inner race of the bearing.
- b) Bearings interference fit to end shield: heat the end shield to a maximum temperature of 140°C, then position the bearing in its housing, push it until it rests against the snap ring.

4.4.3 Checking the bearings

- a) Bearings interference fit to shaft: after assembly has been completed the inner ring of the bearing must rest against the relevant shaft shoulder.
- b) Bearings interference fit to end shield: after assembly has been completed the inner ring of the bearing must rest against the snap ring

4.4.4 Reassembling the motor

Before reassembling, clean the internal parts of the motor carefully and check that the components have not been damaged. Renew the layer of grease where needed on the abutting spigots and proceed with the reassembling.

When needed, all motor components should be replaced by original spare parts. To request spare parts use the technic terms shown in the catalogues and always give:

- motor type
- serial number
- year built

4.5.2 Personnel qualification - Authorized repair shops

Overhauls and repairs must be carried out by trained personnel who guarantee restoration of the motor to its original conditions, we recommend that you contact an authorised repair agent.

For further information please contact our sales department.

4.5 Repairs and Overhauls

4.5.1 Spare parts

5. Troubleshooting

Problem	Possible Cause	Solution
The motor does not start	Fuses damaged due to overloading	Replace the fuses with similar ones of the correct size.
	Opening of the overload switch	Check and reset the switches.
	Insufficient power available	Check that the power required is as shown on the motor's plate.
	Connections incorrect	Check that the connections are as shown in the motor's connection diagram.
	Mechanical fault	Check that the motor and the machine to which it is coupled turn freely. Check the bearings and lubricant.
	Short circuit on the stator	The motor must be rewound.
	Defective rotor	Check whether the bars and the rings are broken, if necessary replace the rotor.
	One phase is down	Check the connection cables.
	Incorrect application	Check the sizing with the manufacturer.
	Overload	Reduce the load.
	Voltage too low	Make sure that the motor is powered at the voltage shown on the plate.
The motor does not reach its nominal speed or the acceleration times are too long and/or absorption excessive	Voltage drop on the line	Check the connections. Check that the cables are of the correct size.
	Excessive inertia	Check the size of the motor.
	Defective rotor	Check the state of the rotor cage. Replace the rotor if necessary.
The motor overheats when working under load	Overloaded	Reduce the load.
	Cooling fins and/or fan cover blocked by dirt	Clear the ventilation slots to ensure a continuous flow of air over the motor.
	One phase on the motor may be down	Check that all the cables are connected tightly and correctly.
	One phase on the winding is earthed	Check the winding and remove the fault.

Problem	Possible Cause	Solution
	Phase voltages asymmetrical	Check the power supply and motor -voltages and rebalance the loads.
	Duty too great	Use the motor for the service indicated on the plate.
Incorrect rotation	Incorrect phase sequence	Invert two phases.
Functioning of the protective device	The motor may have one phase down	Check the power supply.
	Wrong connection	Follow the wiring diagram for the connections and the performance data shown on the plate.
	Overloaded	Compare against the data on the plate and reduce the load if necessary.
Abnormal vibrations	Motor not aligned	Align the motor with the machine it controls.
	Base weak	Reinforce the base. Check the bolts.
	Coupling or pulley not balanced	Balance the device.
	Coupled machine unbalanced	Balance the coupled machine.
	Defective bearings	Replace the bearings.
	Motor balanced differently from the coupling (half key - full key)	Balance the coupling using the half key.
	Three-phase motor working with 1 phase down	Check the phases and reinstate the three-phase system.
	Excessive play on the bearings	Either: -replace the bearings -replace the shield -add a shim to the bearing seating.
Irregular noise	Fan touching the fan cover	Eliminate contact.
	Defective bearings	Replace the bearings.
Bearings overheating	Motor fitted incorrectly	Check that the motor is adequate for the type of fitting.
	Belts over-tensioned	Reduce the belt tension.
	Pulleys too far from the shaft shoulder	Move the pulley nearer to the shoulder on the motor shaft.
	Pulley diameter too small	Use a bigger pulley.
	Alignment incorrect	Correct the alignment of the motor and the machine coupled to it.

Problem	Possible Cause	Solution
	Insufficient grease	Keep the correct amount of lubricant in the bearings.
	Lubricant ineffective or contaminated	Remove the old grease, wash contaminated bearings carefully and grease with new lubricant.
	Excessive lubricant	Reduce the amount of lubricant. The bearing must not be more than half full.
	Bearing overloaded	Check the alignment and any radial and/or axial thrust.
	Bearing balls or race damaged	Replace the bearing.

Motor spare part list

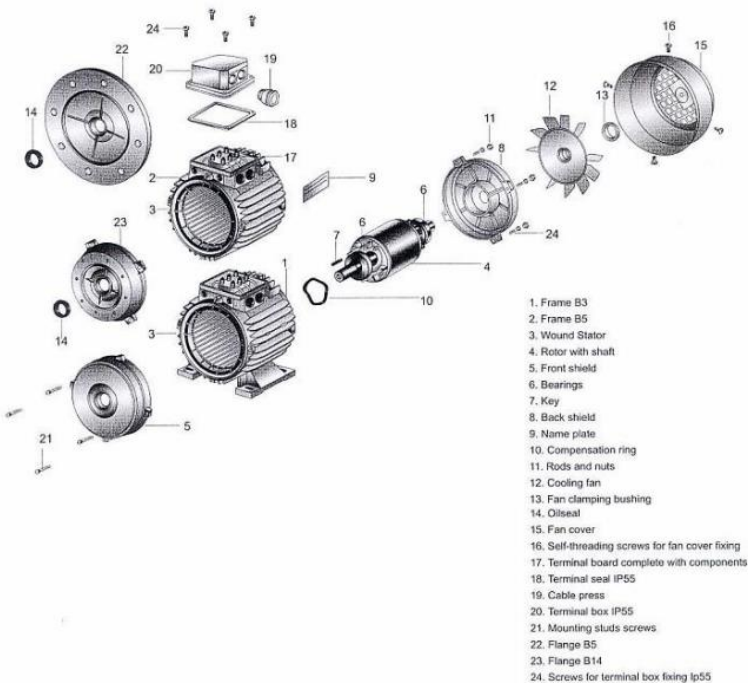

Connecting diagrams - Table A

Connection for single speed motors:

Y-Connection

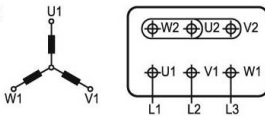

Connection-A

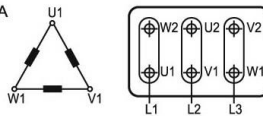

Number of pole: 2, 4, 6, 8....-Synchronous speed at 50 Hz: 3000, 1500, 1000, 750....

Two separate windings for two speed motors:

High Speed

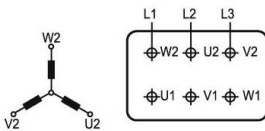

Low Speed

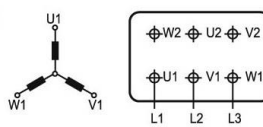

Number of pole: 2/6, 2/8, 4/6, 6/8....-Synchronous speed at 50 Hz: 3000/1000, 3000/750, 1500/1000, 1000/750....

Dahlander system for two speed motors, constant torque:

High Speed

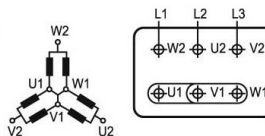

Low Speed

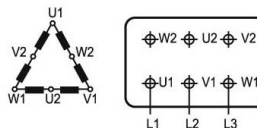

Number of pole: 2/4, 4/8 -Synchronous speed at 50 Hz: 3000/1500, 1500/750

Dahlander system for two speed motors, quadratic torque:

High Speed

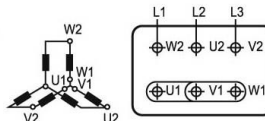

Low Speed

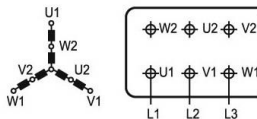

Number of pole: 2/4, 4/8 -Synchronous speed at 50 Hz: 3000/1500, 1500/750

Connection for single-phase and special motors.

For single-phase motors and motors with special connections, refer to the diagrams provided with the motor.

Lubrication intervals in hours for unshielded bearings - Table B

Ball bearings		Lubrication intervals in duty hours						
Frame size	Amount of grease g	3600 r/min	3000 r/min	1800 r/min	1500 r/min	1200 r/min	1000 r/min	500-900 r/min
112.132	15	4200	4800	7000	7800	8500	10000	10500
160.180	20	3200	4200	6000	7000	8000	9000	10000
200.225	25	1800	3100	5500	6500	7500	8500	9500
250.280	35	800	2000	5000	6000	7000	8000	9000
315	50	800	2000	4600	5500	6500	7500	8000
355.400	60		1000	4000	5000	6000	7000	8000

MS: 4POLE/1500rpm

Technical Specifications

Wonder Motor Type MS=cast aluminum series Motor Size acc.to IEC-DIN	Rated output power pn kw	full-load current			Rated speed n _n min ⁻¹	full-load power factor cos φ	Full-load efficiency η %	locked rotor current Ia/In	locked rotor torque M _{st} /M _n	break down torque M _b /M _n	moment of inertia J kgm ²	net weight m kg
		380V lu A	400V lu A	420V lu A								
MS5614	0.06	0.28	0.26	0.26	1200	0.65	50.0	4.0	1.4	2.0	0.000064	3.2
MS5624	0.09	0.37	0.35	0.33	1200	0.73	50.0	4.0	1.8	2.0	0.000070	3.4
MS6314	0.12	0.44	0.42	0.40	1220	0.72	57.0	4.0	1.8	2.0	0.000117	4.0
MS6324	0.18	0.64	0.62	0.58	1220	0.73	58.0	4.0	1.8	2.0	0.000136	4.5
MS7114	0.25	0.79	0.75	0.71	1345	0.74	65.0	5.2	2.2	2.1	0.000423	6.1
MS7124	0.37	1.10	1.06	0.99	1340	0.75	67.0	5.8	2.2	2.1	0.000468	6.7
MS8014	0.55	1.57	1.49	1.42	1390	0.77	71.0	5.3	2.2	2.5	0.001146	8.9
MS8024	0.75	2.03	1.93	1.84	1380	0.77	73.0	5.3	2.3	2.5	0.001263	9.6
MS90S4	1.1	2.90	2.80	2.70	1390	0.75	77.4	4.7	2.3	2.5	0.002761	12.5
MS90L4	1.5	3.82	3.60	3.46	1390	0.76	78.5	5.2	2.3	2.5	0.003283	15.0
MS100LA4	2.2	5.00	4.80	4.60	1415	0.81	81.0	6.8	2.3	2.5	0.003119	19.2
MS100LB4	3.0	6.70	6.40	6.10	1415	0.82	82.6	7.1	2.3	2.5	0.004704	23.0
MS112M4	4.0	8.70	8.30	7.90	1430	0.82	85.0	6.4	2.3	2.6	0.006418	29.0
MS132S4	5.5	11.70	11.10	10.60	1445	0.83	85.7	7.0	2.3	2.5	0.013249	43.5
MS132M4	7.5	15.50	14.80	14.10	1445	0.84	87.0	7.0	2.3	2.5	0.016912	53.5

All technical details based on 380/50Hz.

MS56-132.B34

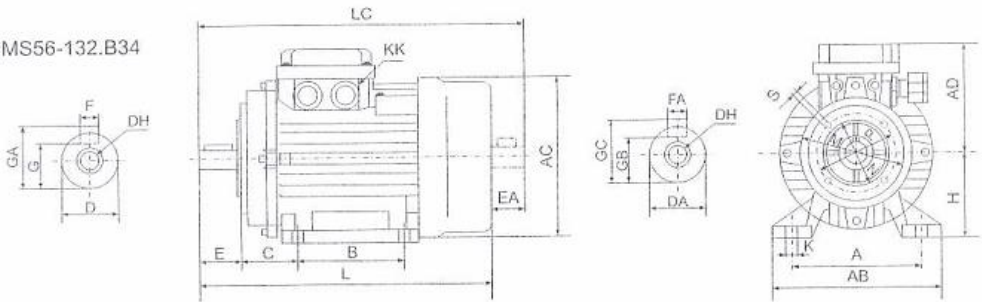

Frame	A	AB	AC	AD	B	C	D	DH	E	F	G	H	K	KK	L	M	N	P	S	T	DA	EA	GC	GB	GA	FA
MS56	90	110	110	96	71	36	9	M4×12	20	3	7.2	56	12	2-M18×1.5	189	65	50	80	M5	3	9	20	10.2	7.2	10.2	3
MS63	100	122	122	98	80	40	11	M4×12	23	4	8.5	63	13	2-M18×1.5	218	75	60	90	M5	3	11	23	12.5	8.5	12.5	4
MS71	112	136	138	109	90	45	14	M5×12	30	5	11	71	13	2-M18×1.5	250	85	70	105	M6	3.5	14	30	16	11	16	5
MS80	125	154	157	112	100	50	19	M6×16	40	6	15.5	80	13	2-M20×1.5	278	100	80	120	M6	3.5	14	30	16	11	21.5	5
MS90S	140	174	175	120	100	56	24	M8×19	50	8	20	90	17	2-M20×1.5	³²⁰ / _{335_{min}}	115	95	140	M8	3.5	19	40	21.5	15.5	27	6
MS90L	140	174	175	120	125	56	24	M8×19	50	8	20	90	17	2-M20×1.5	335	115	95	140	M8	3.5	19	40	21.5	15.5	27	6
MS100L	160	194	196	139	140	63	28	M10×22	60	8	24	100	23	2-M20×1.5	377	130	110	160	M8	4	28	60	31	24	31	8
MS112M	190	224	220	156	140	70	28	M10×22	60	8	24	112	22	2-M20×1.5	395	130	110	160	M8	4	28	60	31	24	31	8
MS132S	216	256	260	185	140	89	38	M12×28	80	10	33	132	21	2-M25×1.5	472	165	130	200	M10	4	38	80	41	33	41	10
MS132M	216	256	260	185	178	89	38	M12×28	80	10	33	132	21	2-M25×1.5	510	165	130	200	M10	4	38	80	41	33	41	10

FRAME SIZE	POLES	DRIVING END BEARINGS	NON DRIVING END BEARINGS	OILCEAL	PG THREAD
56	2/4	6201ZZ-C3	6201ZZ-C3	Ø12×Ø22×5	PG11
63	2/4	6201ZZ-C3	6201ZZ-C3	Ø12×Ø22×7	PG11
71	2/4/6	6202ZZ-C3	6202ZZ-C3	Ø15×Ø25×7	PG11
80	2/4/6/8	6204ZZ-C3	6204ZZ-C3	Ø20×Ø30×7	PG13.5
90	2/4/6/8	6205ZZ-C3	6205ZZ-C3	Ø25×Ø37×7	PG16
100	2/4/6/8	6206ZZ-C3	6206ZZ-C3	Ø30×Ø42×7	PG16
112	2/4/6/8	6206ZZ-C3	6206ZZ-C3	Ø30×Ø42×7	PG21
132	2/4/6/8	6308ZZ-C3	6308ZZ-C3	Ø40×Ø58×8	PG21

Client :
Purchase order :
Purchase date :
Delivery date :

We, NTF Filter bv, declare, under own responsibility, that this product with serial number

to which this declaration is related, complies with all appropriate regulations and is in conformity with:

- the standard directive 2006/42/EU of the European parliament and the Council of 17 May 2006 concerning machinery and the modification of directive 95/16/EU (directive).
- the standard directive 2014/35/EU of the European Parliament and the Council of 20 april 2016 concerning the mutual adaptation of the legal regulations of the Member States concerning electric material intended for use within stipulated tension borders. (low tension directive).

Rotterdam, The Netherlands

Date :
Name :
Function :